

Company :

Name :

Fax :

Phone :

Reference :

## EXTRUSION TEMPERATURE CONTROL

**EXTRUDER TYPE:** Single screw

Double screw

### SELECT CYLINDER TYPE:

Heating and cooling needed

Only cooling needed

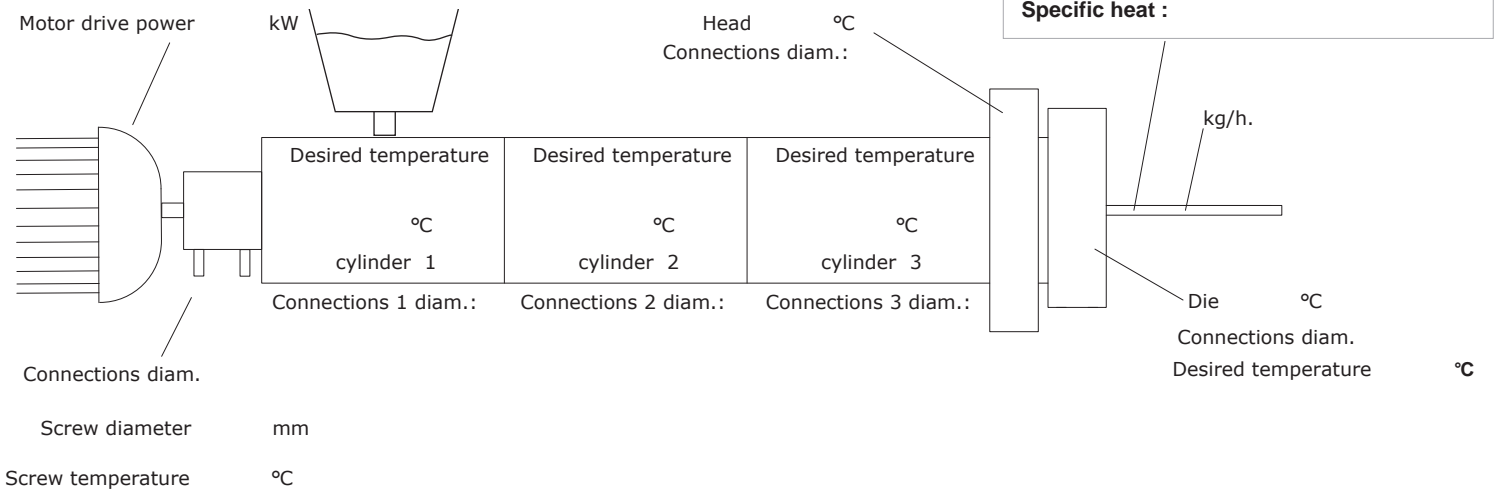
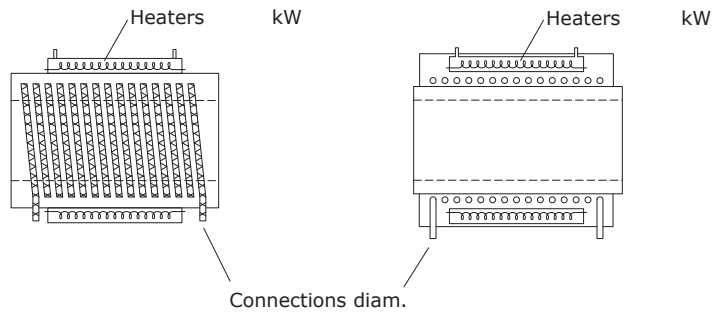
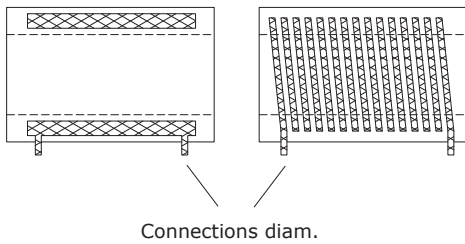

Material type :  
 Specific weight :  
 Specific heat :

Fluid	content in the screw	litres:
Fluid	content in cylinder 1	litres:
Fluid	content in cylinder 2	litres:
Fluid	content in cylinder 3	litres:
Fluid	content in head	litres:
Fluid	content in die	litres:

water temperature °C  
 water pressure bar

Voltage V Hz

